

MANUAL REGENERATION

NOTE: For softeners, if brine tank does not contain salt, fill with salt and wait at least 2 hours before regeneration.

If you need to initiate a manual regeneration, either immediately, or tonight at the preprogrammed time for regeneration (typically 2:00), complete the following steps.

For Immediate Regeneration:

Press and hold "REGEN" until valve motor starts (typically 3 seconds).

For Regeneration Tonight:

Press and release "REGEN" (notice that flashing "REGEN TODAY" appears).

REGEN TODAY will flash if a regeneration is expected "Tonight."

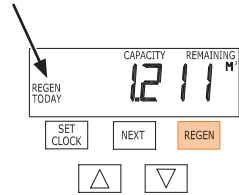

If the display toggles between "Error" and an error code (i.e. a number), call a service technician and report the error code.

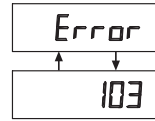

To **shut-off water** to the system, please position arrow handles as shown in the **bypass operation** diagram below. If your valve doesn't look like the diagram below, contact your service technician for instructions on how to shut-off water.

NORMAL OPERATION

Treated Water Exits
Supply Water Enters

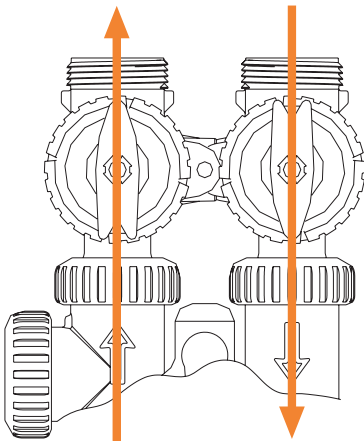

BYPASS OPERATION

Supply Water Exits
Supply Water Enters

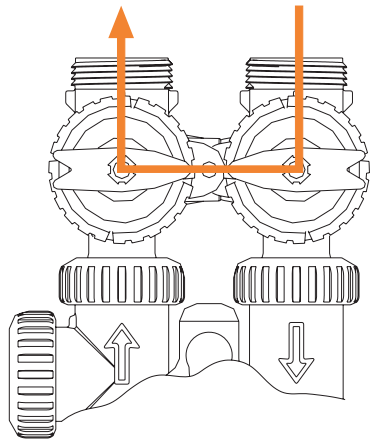

NOTES:

Installation date: _____

Injector color installed: _____

Drain Control size installed: _____

Hardness: _____

Water pressure: _____

Salt setting: _____

Iron (ppm): _____

Manganese (ppm): _____

TDS (ppm): _____

pH: _____

GENERAL OPERATION

When the system is operating, one of two display groups will be shown: Time of Day, Treated Water Flow Rate and Capacity Remaining or Time of Day, Treated Water Flow Rate and Days Remaining. Pressing "NEXT" will toggle between the choices.

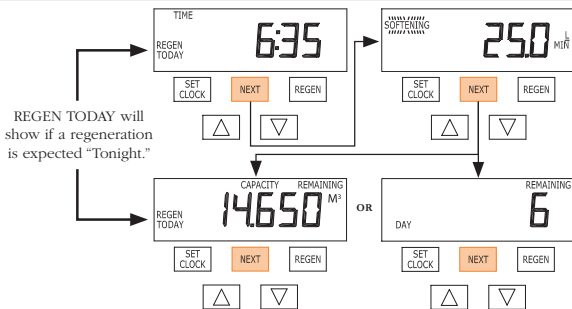

TO SET TIME OF DAY

In the event of a prolonged power outage, time of day flashes, indicating that this needs to be reset. All other information will be stored in memory no matter how long the power outage. Please complete the steps as shown to the right. To access this mode, press "SET CLOCK."

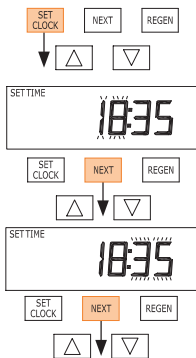

1. Accessed by pressing "SET CLOCK."
2. Adjust hours with ▲ or ▼ button.
3. Press "NEXT."
4. Adjust minutes with ▲ or ▼ button.
5. Press "NEXT" to complete and return to normal operation.

ADJUST HARDNESS, DAYS BETWEEN REGENERATIONS, OR TIME OF REGENERATION

For initial set-up or to make adjustments, please complete the steps as shown to the right. Access this mode by pressing "NEXT" and "▲" simultaneously.

NOTE: Hardness display shows "-nA-" if used as a filter or if volume was placed directly in System Set Up. If other displays do not appear, refer to manual.

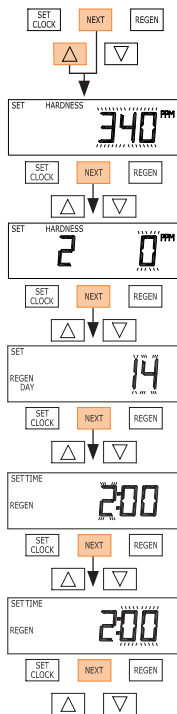

1. Accessed by pressing "NEXT" and ▲ simultaneously.
2. Adjust hardness using ▲ or ▼ button. Units may be in German degrees, French degrees, or parts per million.
3. Press "NEXT."
4. If using a mixing valve, set the amount of effluent hardness using the ▲ or ▼ button.
5. Press "NEXT."
6. Adjust days between regenerations using ▲ or ▼ button.
7. Press "NEXT."
8. Adjust time of regeneration hour with ▲ or ▼ button.
9. Press "NEXT."
10. Adjust time of regeneration minutes with ▲ or ▼ button.
11. Press "NEXT" to complete and return to normal operation.